



walvoil
MOTION BY PEOPLE

NEW

PWLS

Variable Displacement Piston Pumps

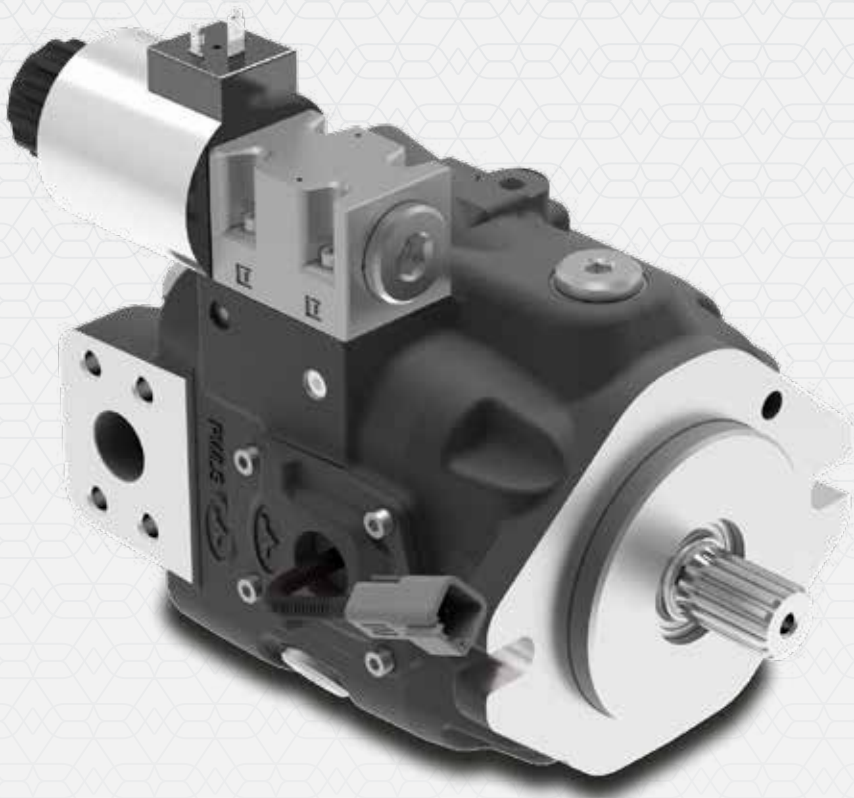

PWLS VARIABLE DISPLACEMENT PISTON PUMPS

- Heavy duty operation
- Compact tandem design
- Different displacement control solutions
- Sensor installation
- ALS Adaptive control



Walvoil presents PWLS, the new range of Variable Displacement Piston Pumps.

PWLS series offers all the features needed for a new generation of mobile hydraulic pumps.

Its compact design allows the installation in narrow spaces, its reactivity and stability grant the maximum comfort for the operator.

The design and production cycle allows heavy duty operation in the medium pressure range, with a nominal service pressure up to 280 bar (4050 psi).

Additional features, like sensors cavities, compact tandems and various control manifolds complete the offer of this new generation of Walvoil piston pumps.



WORKING CONDITIONS

Suction pressure		from 0,8 to 2 bar <i>from 11.6 to 29 psi</i>
Fluid		hydraulic mineral oil-based
Fluid temperature	With NBR (buna N) seals	from -20 to +80 °C <i>from -4 to +176 °F</i>
Viscosity	Recommended	from 15 to 92 mm ² /s (cSt)
	Permitted for starting	2000 mm ² /s (cSt)
Max level of contamination	Recommended for operating pressure > 150 bar (2150 psi)	20/18/15 ISO 4406 class 9 (NAS 1638)
	Recommended for operating pressure < 150 bar (2150 psi)	21/19/16 ISO 4406 class 10 (NAS 1638)

TECHNICAL DATA

PWLS series	Max. displacement		Max working pressure		Max peak pressure		Max rotation speed rpm	Weight	
	cm ³ /rev	in ³ /rev	bar	psi	bar	psi		kg	lb
PWLS5	min.	41	280	4.050	320	4.650	500-3000	22.5	49.6
	std.	53	280	4.050	320	4.650	500-2600		
	max.	56	280	4.050	320	4.650	500-2400		
PWLS7	min.	56	280	4.050	320	4.650	500-2900	25.9	57.1
	std.	72	280	4.050	320	4.650	500-2600		
	max.	80	250	3.600	300	4.350	500-2200		

DIMENSIONAL DATA

The dimensional drawings represent the version with SAEB flange (for other flanges, please contact our Sales Department).

PWLS5 pump

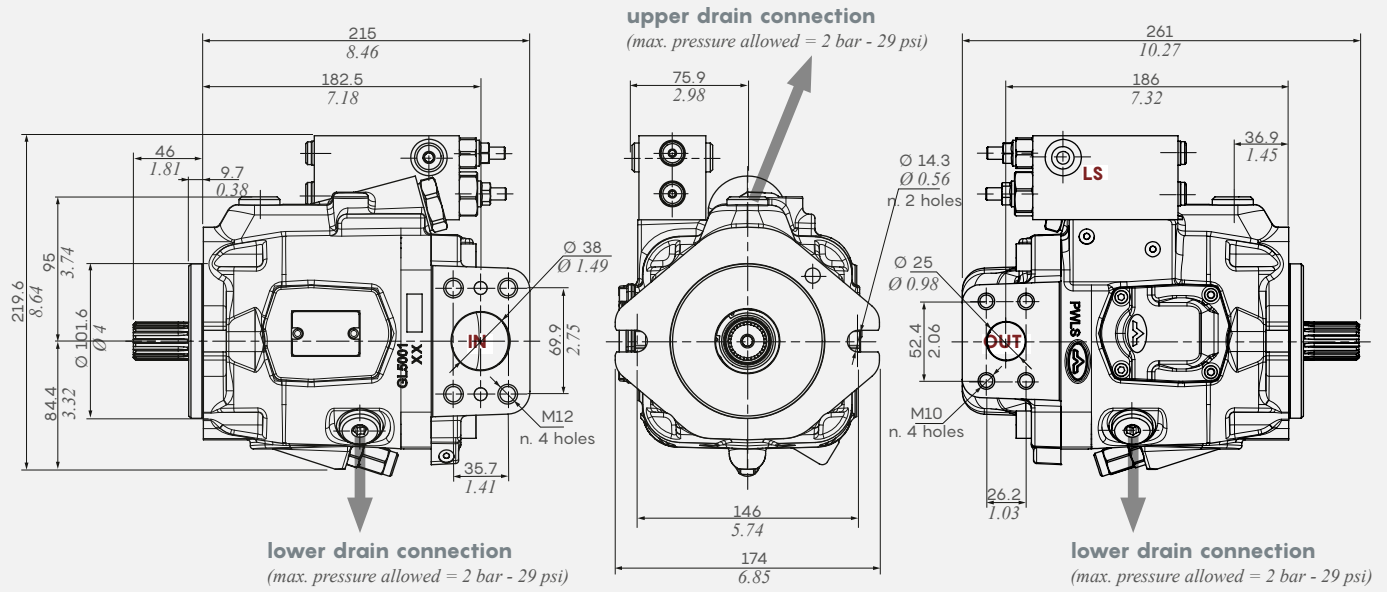

PWLS7 pump

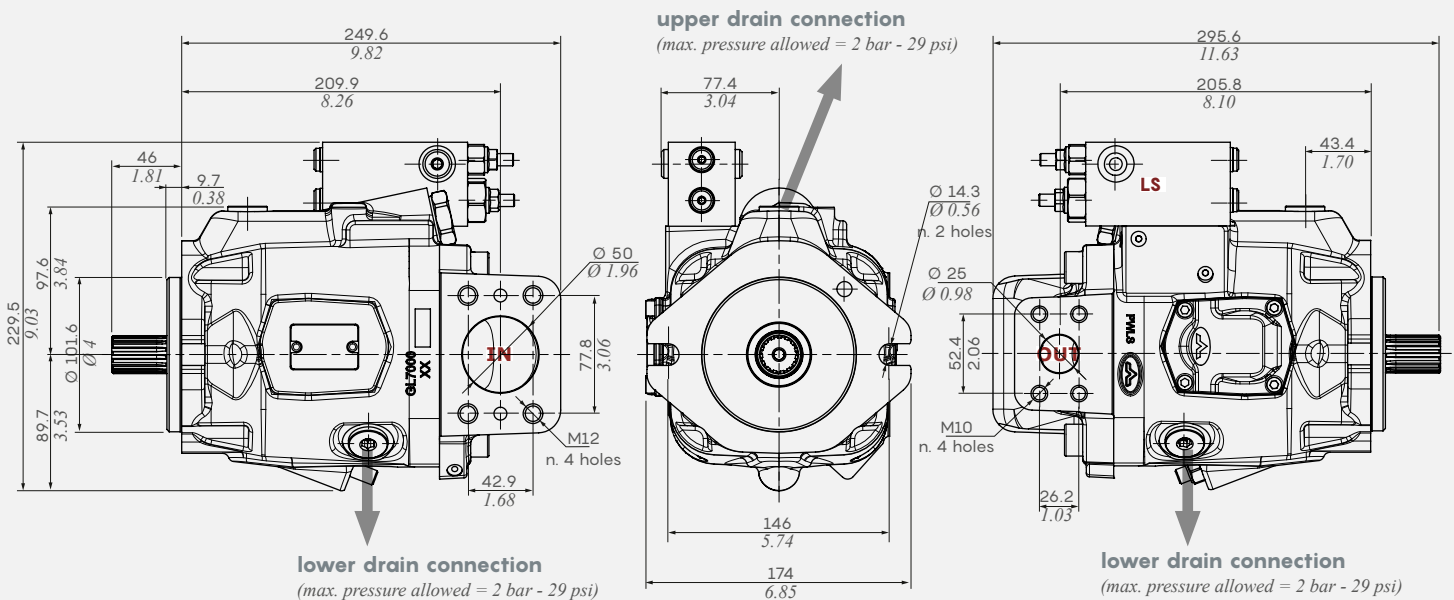

Note: PWLS pumps have to be connected to a separate drain.

DISPLACEMENT SET-UP

PWLS7 example

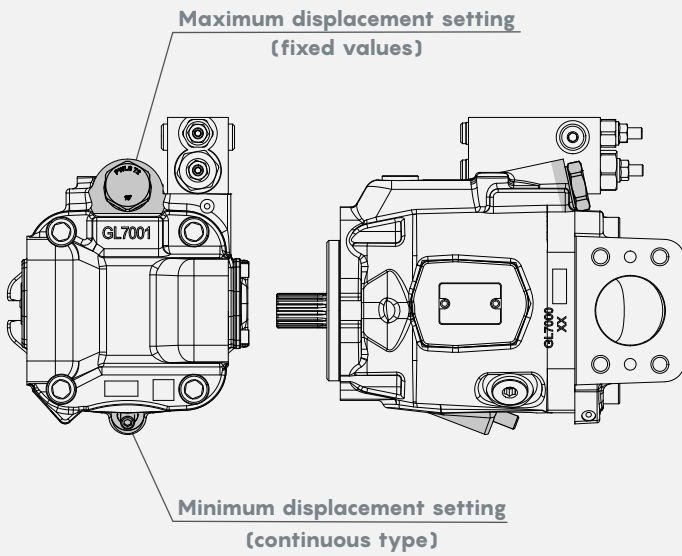

	Maximum displacement setting		Minimum displacement setting	
	cm ³ /rev	in ³ /rev	cm ³ /rev	in ³ /rev
PWLS5	min.	41	from 0 to 10	<i>from 0 to 0.61</i>
		44		
		47		
		50		
	std.	53		
	max.	56		
PWLS7	min.	56	from 0 to 10	<i>from 0 to 0.61</i>
		60		
		64		
		68		
	std.	72		
	max.	80		

COVER OPTIONS

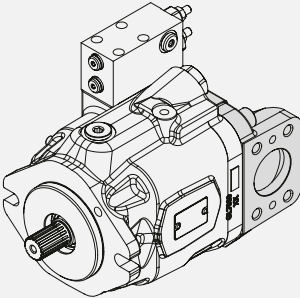
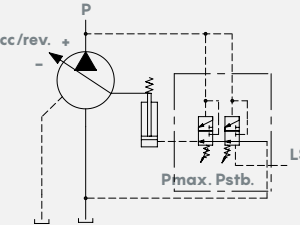
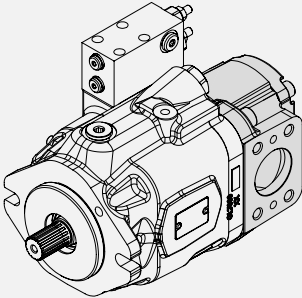
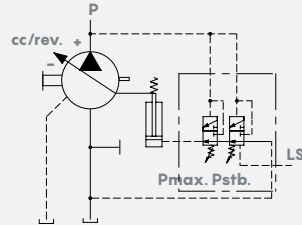
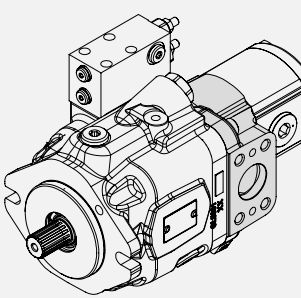
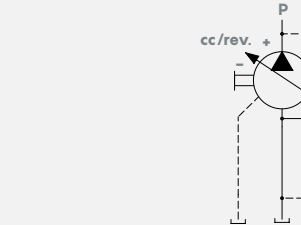
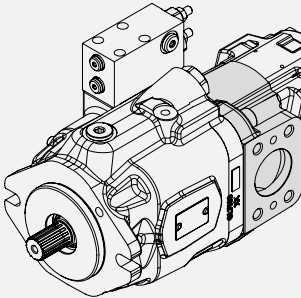
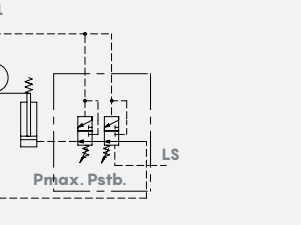
Single pump PWLS	Single pump Dealer type PWLS	Two stages pump PWLS + 2XP	Two stages pump PWLS + 2XPW
 	 	 	 

DISPLACEMENT CONTROL OPTIONS

PWLS product range is now available with three different type of displacement control.

LS control is the traditional load sensing control, aimed to keep a constant pressure margin through the main control valve.

In this kit a max pressure limiter is also included, able to minimize the displacement in case of setting pressure reached by the actuator.

LS-TL control complete the offer of LS control.

The additional torque limiter reduces automatically the displacement of the pump in case high torque is required by the circuit.

This function is used to prevent stall of the thermal engine.

ALS control gives the ECU the possibility to adjust the operating displacement in order to follow a determined displacement or a virtual pressure margin. This feature allows to reduce energy consumption in idle speed and to be more precise in the actuation when needed by the operator.

LS
Load Sensing system

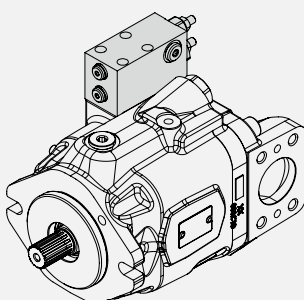

LS-TL
Mechanical torque control

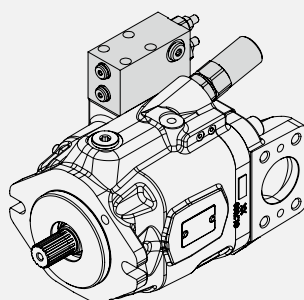

ALS
Adaptive Load Sensing system

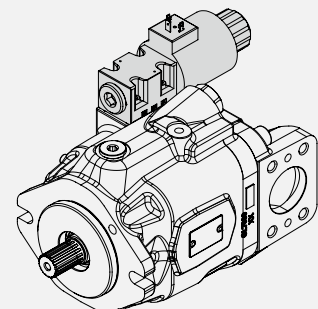

SWASHPLATE WINDOW

All PWLS pumps have the predisposition for sensor installations. Three type of sensors can be individually or simultaneously connected to the side of the pump. The swashplate angle is measured to evaluate the pump operating displacement. In the same cavity also the speed of the pump can be measured, providing to the ECU all the

information about the delivered flow rate. A third pressure sensor allows to measure the pressure of the delivered flow. All together these three indicators permit to evaluate the torque and the power request from the implement during operations.

Angle sensor

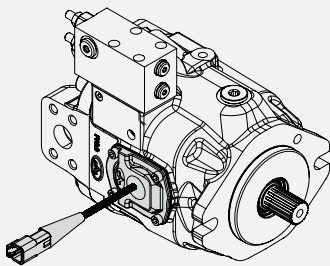

Speed sensor

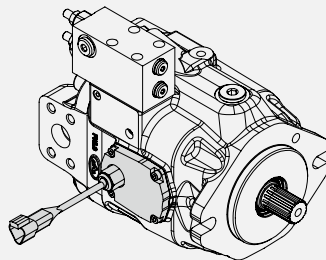

Working pressure sensor

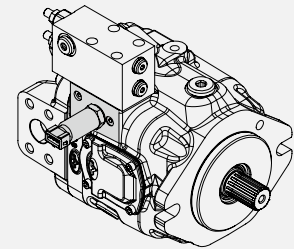

PORTS AND CONNECTIONS

	Type	Suction port (Inlet)	Delivery port (Outlet)	Drain ports (x3)
PWLS5	F114F1G12	1 1/2" (ISO 6162-1) 4 x M12x1.75 (depth 20) Ø 38	1" (ISO 6162-1) 4 x M10x1.5 (depth 18) Ø 25	BSP 1/2" 3/4-16 UNF (SAE8)
PWLS7	F2F1U10	2" (ISO 6162-1) 4 x M12x1.75 (depth 20) Ø 50	1" (ISO 6162-1) 4 x M10x1.5 (depth 18) Ø 25	BSP 3/4" 7/8-14 UNF (SAE10)

Note: For other connections, please contact our Sales Department

SHAFT TYPES

Type S13

(only for PWLS5)

Torque 280 Nm / 206 ft-lbs

Splined profile:

SAE J498B type 13T - 16/32 pitch - 30°

Type S13N

(only for PWLS7)

Torque 300 Nm / 221 ft-lbs

Splined profile:

SAE J498B type 13T - 16/32 pitch - 30°

Type S15

Torque 400 Nm / 296 ft-lbs

Splined profile:

SAE J498B type 15T - 16/32 pitch - 30°

Type S15N

Torque 420 Nm / 309 ft-lbs

Splined profile:

SAE J498B type 15T - 16/32 pitch - 30°

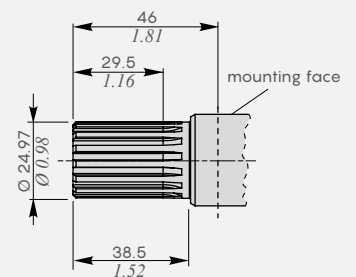
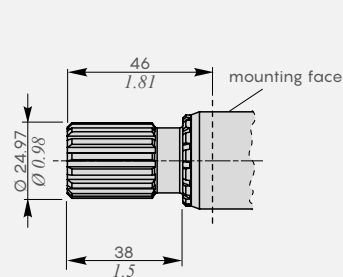
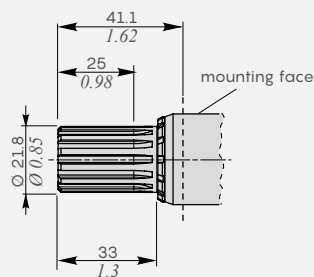
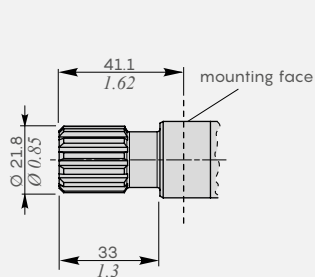

Note: For other shaft options, please contact our Sales Department

DESCRIPTION COMPOSITION

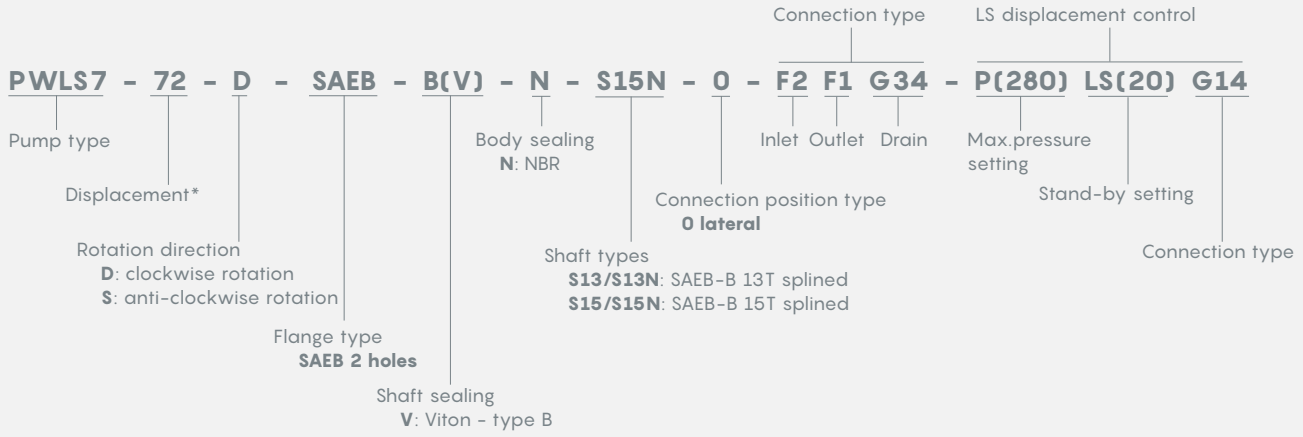

Note[*]: For displacement types, see "technical data" table

