



DPC 130X

Pre-compensated Load Sensing
sectional valves - ATEX version

TECHNICAL CATALOGUE



Additional information

This catalogue shows the product in the most standard configurations.
Please contact Sales Dpt. for more detailed information or special request.

WARNING!

All specifications of this catalogue refer to the standard product at this date.
Walvoil, oriented to a continuous improvement, reserves the right to
discontinue, modify or revise the specifications, without notice.

WALVOIL IS NOT RESPONSIBLE FOR ANY DAMAGE CAUSED BY AN
INCORRECT USE OF THE PRODUCT.

2nd edition September 2018

The DPC Series

The DPC Series is a family of open/closed center pre-pressure compensated sectional valves designed specifically for Mobile Applications. The DPC series provides exceptional controllability, efficiency and flexibility for applications requiring up to 240 l/min (63.4 US gpm) flow rate. DPC Series is available in two different sizes: DPC130 (DPC130X) and DPC200.

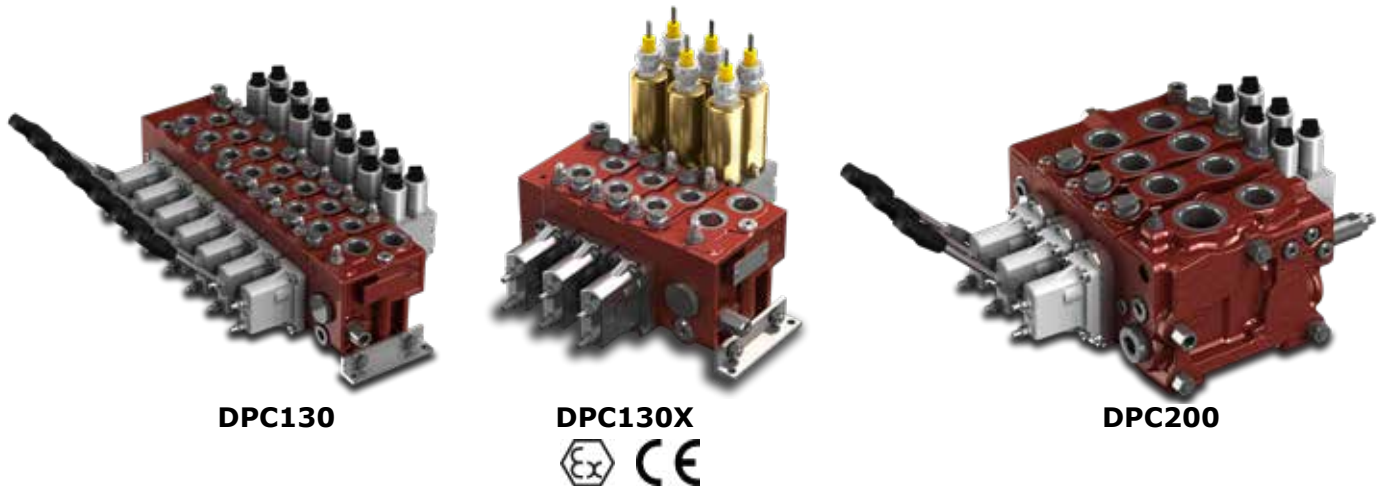

The Load Sensing technology

Thanks to the use of specially designed pumps and control valves, the Load Sensing principle can be considered the most comprehensive means of creating a flexible hydraulic circuit that can adapt to the various operating conditions demanded by users. The main feature of this principle is that the flow rate to the user is proportional to the spool position under any operating condition, regardless of the resistance encountered by the user (pressure) and the number of levers activated (exceeding the pump's total flow rate, a condition here in after defined as saturation, is the only limitation).

Therefore, with the LS systems, there is a specific correspondence between the position of the control lever and the movement speed of the user, cylinder or hydraulic motor. This feature is particularly useful in the hydraulic handling machine sector (excavators, cranes, loaders, agricultural and forestry machinery) in which each movement phase has specific sequences that the operator must control by using memorised movements.

Advantages and options

- Energy saving.
- Extension of part service life.
- Lower energy dissipation.
- Noise reduction.
- Available to create a single-pump circuit (compared with the use of multiple-pump circuits in which each pump is dedicated to different actuators to be operated simultaneously).

Real energy savings can be obtained above all when the DPC directional valves operate together with variable displacement Load Sensing pumps. When the DPC valve is utilised with fixed displacement pumps, the previously mentioned movement independence and repeatability features are guaranteed, but energy savings will be limited.

For special options please contact Sales Dept.

The ATEX version

The DPC130X is the DPC Series new valve built according to the ATEX directive for safe use in classified areas, with inflammable and potentially explosive materials.

Hydraulic features and performance remain the same of the DPC130 standard valve.

Contents

Working conditions	page 5
Standard threads	5
ATEX directive introductions.	6
Explosion risk assessment	8
Dimensional data and performance.	10
Complete section ordering codes	11
• Inlet section	
Solenoid operated L.S. unloading valve	12
• Working section	
"A" side spool control kit	13
"B" side spool control kit	16
• Installation	17

Working conditions

This catalogue shows technical specifications and diagrams measured with mineral oil of 46 mm²/s - 46 cSt viscosity at 40°C - 104°F temperature.

Nominal flow rating (open center circuit)	on inlet port with compensator @ stand-by (margin pressure)	150 l/min - 39.6 US gpm @ 9 bar - 131 psi
	on working ports with compensator @ stand-by (margin pressure)	100 l/min - 26.4 US gpm @ 7 bar - 102 psi
	on working ports without compensator @ stand-by (margin pressure)	130 l/min - 34.3 US gpm @ 9 bar - 131 psi
Max. pressure	P inlet port	315 bar ⁽¹⁾ - 4500 psi ⁽¹⁾
	A and B working ports	315 bar ⁽¹⁾ - 4500 psi ⁽¹⁾
Back pressure (max.)	on T outlet port	25 bar - 363 psi
	on L drain port	2.5 bar - 36 psi
Standard internal leakage A(B)->T	Δp=100 bar - 1450 psi	16 cm ³ /min - 0.98 in ³ /min
	with port valves, Δp=100 bar - 1450 psi	21 cm ³ /min - 1.28 in ³ /min
Fluid		Mineral oil
Fluid temperature range	with seals NBR (BUNA-N)	from -20°C to 80°C - from -4°F to 176°F
	with seals FPM (VITON)	from -20°C to 80°C - from -4°F to 176°F
Viscosity	operating range	from 15 to 75 mm ² /s - from 15 to 75 cSt
	min.	12 mm ² /s - 12 cSt
	max.	400 mm ² /s - 400 cSt
Contamination level	max.	-/18/15 - ISO 4406 - NAS 1638 class 9
Environmental temperature for working conditions	without solenoid operated unloader valve	from -20°C to 60°C ⁽²⁾ - from -4°F to 140°F ⁽²⁾
Environmental pressure for working conditions		from +0.8 to + 1.1 bar - from +11.6 to 16 psi

NOTES: ⁽¹⁾ According to NFPA T 2.6.1., fatigue rating verified for 1 million cycles on 6 sample valves with test Pressure = 1.23 x Max. pressure indicated - ⁽²⁾ DPC130X can operate with gases with an ignition temperature above 135°C - 275°F and powders with an ignition temperature above 130°C - 266°F.

Standard thread

REFERENCE STANDARD	BSP		UN-UNF	
	BSP	UN-UNF	BSP	UN-UNF
THREAD	ISO 228/1	ISO 263		
ACCORDING TO	BS 2779	ANSI B1.1 unified		
CAVITY	ISO 1179	11926		
DIMENSION	SAE	J1926		
ACCORDING TO	DIN 3852-2, X or Y shape			
PORTS				
P inlet	G 3/4	1 1/16-12 (SAE 12)		
A and B ports	G 1/2	7/8-14 (SAE10)		
T outlet	G 3/4	1 1/16-12 (SAE 12)		
LS Load Sensing	G 1/4	9/16-18 (SAE 6)		
V1 pilot	G 1/4	9/16-18 (SAE 6)		
V2 pilot	depends on inlet section type: see pages from 14 to 17 ⁽⁵⁾			
L drain	G 1/4	7/16-20 (SAE 4)		
M pressure gauge	G 1/4	9/16-18 (SAE 6)		
Hydraulic control ports	G 1/4	9/16-18 (SAE 6)		

NOTES ⁽⁵⁾: ATTENTION! V2 pilot port requires dedicated joints; please see Inlet section pages.

Valve description

ATEX Directive 2014/34/UE

The ATEX Directive 2014/34/UE is applied, with the aim to reduce the risk of use, to the manufacture specifications of all those products to be used in potentially explosive atmosphere due to the presence of dust or gas. According to this directive an explosive atmosphere is made up from a mixture of inflammable substances (like gas, vapours, mists and dust) with air in determined atmospheric conditions in which, after triggering, the combustion propagates together with unburned substances. An atmosphere that could become an explosive atmosphere because of local and/or operative conditions is defined a potentially explosive atmosphere.

In order to define an adequate conformity evaluation procedure, depending on the purpose stated, the manufacturer must establish the product functioning conditions (e.g. for the working area, the type of the possible explosive mixture and the risk level of an explosive atmosphere), then to which Group the product belong and determine the category inside the Group.

Areas	Gas-Air-type explosive mixture (G)	Dust-Air-type explosive mixture (D)
With the Atex Directive 2014/34/UE (for the safety of workers) please find the working conditions for products in compliance with Atex Directive 2014/34/UE. These are expressed in Areas and defined according to the potential explosive atmosphere, respectively for every type of atmosphere (gas-air mix or dust-air mix).	The products due to work in environments characterized by this type of explosive atmosphere will be respectively indicated for Area 0, 1 or 2 depending on the Group and category of origin (see below) and they are marked with the letter G.	The products due to work in environments characterized by this type of explosive atmosphere will be respectively indicated for Area 20, 21 or 22 depending on the Group and category of origin (see below) and they are marked with the letter D.
Area 0 and 20		
Where an explosive atmosphere is constantly present or present for long periods or frequently.		
Area 1 and 21		
Where an explosive atmosphere is probable. It occurs in normal functioning and exercise conditions.		
Area 2 and 22		
Where an explosive atmosphere is scarcely possible or, if it occurs, it lasts only for a brief period of time.		

ATEX directive introduction

Group I	Group II
Includes the appliances destined to be used in underground jobs in the mines and their surface plants, exposed to the risk of the release of firedamp and/or combustible dust. The sub-division into categories depends on the fact if the power supply must be interrupted or not if an explosive atmosphere manifests due to a mixture of air and gas, vapours mists (D) or a mixture of air and dust (G).	Includes appliances destined to be used in different environments (from the mines) in which there is a probability that an explosive atmosphere manifests itself. Their subdivision into categories depends on two factors: the place, where the product will be used and if the probability that a potentially explosive atmosphere, owing to the mixture of air and gas, vapours, mists (D) and the mixture of air and dust (G), comes about in a constant or occasional manner and if it does occur, does this possibility remain for long or brief period of time.
Category M1: Very high protection level	Category 1: Very high protection level
These products must be able to remain operative, for safety reasons, in the presence of an explosive atmosphere and present specific performances or protection configurations for breakdown in case of explosion.	These products must be planned to function in compliance with operative parameters established by the Manufacturer in environments in which there is a high probability that explosive atmospheres are always detected or manifest often or for long periods of time. They must present specific performances or protection configurations for breakdown in case of explosion.
Category M2: High protection level	Category 2: High protection level
The power supply to these products must be interrupted in the presence of an explosive atmosphere. Protection means must be incorporated to guarantee the level of protection during normal functioning and also in oppressive working conditions or resulting from great stress.	These products must be planned to function in compliance with operative parameters established by the Manufacturer in environments in which there is a high probability that explosive atmospheres can manifest. Protection against explosions relative to this category must Function in a way to guarantee the required safety level even in the presence of functioning defects of the appliances or in dangerous operative conditions, which frequently must be taken into consideration.
	Category 3: Normal protection level
	These products must be planned to function in compliance with operative parameters established by the Manufacturer in environments in which there is a slight probability that explosive atmospheres can manifest, and however only rarely or for a brief period of time. This type of product belonging to the category in question must guarantee the safety level required in normal functioning condition.

Explosion risk assessment

Equipment description

The DC130 sectional control valves, manufactured by Walvoil S.p.A, included in the equipment definition stated by the Directive ATEX2014/34/UE published on February 26th and which is to be effective from April 20th 2016.

The Directive defines the equipment as "[...] machines, materials, fixed or mobile devices, control components, instrumentation and detection or prevention systems which, separately or jointly, are intended for the generation, transfer, storage, measurement, control and conversion of energy and/or the material processing and which are capable of causing an explosion because of their own potential sources of ignition".

According with this definitions the Walvoil SpA DPC130X sectional control valves, are not able to work properly if they are not previously connected to a hydraulic feeding line and in some cases to an electrical one.

The Walvoil SpA DPC130 Series, in compliance with the Directive ATEX, is composed by different valve types whose dimensions may change but not their working principle.

Electric/hydraulic components installed on Walvoil DPC130X, are to be considered as commercial components, marked ATEX, purchased from different suppliers and suitable to the area of use.

Please find in this catalogue the environmental conditions for DPC130X sectional valve assembling.

Use conditions

Walvoil DPC130 valves are manufactured for open/closed center hydraulic circuits and they are specifically designed specifically for Mobile Machines Applications.

The standard operating conditions are the environmental ones, with atmospheric pressure from + 0.8 to +1.1 bar (*from 11.6 to 16 psi*) and environmental temperature from -20°C to +60°C (*from -4°F to 140°F*).

The temperature range of the operating fluid is from -20°C to +80°C (*from -4°F to 176°F*).

Because of the possibility that this equipment is used in environments classified for the presence of flammable gases or combustible dusts, or in mines and in their surface plants, which may be exposed to the risk of firedamp and/or combustible dusts, it is necessary to elaborate an accurate risk assessment in order to avoid that this equipment becomes an of ignition source.

This risks is aimed at making the equipment suitable for installation in an environment classified as AREA 1 for the presence of flammable gases or as AREA 21 for the presence of combustible dust, or in mining environment which may be potentially explosive:

category II 2G
category II 2D
category I M2

(Main) reference sources

Legislative Body

- Directive ATEX 94/9/CE: Directive of European Parliament and of the Council of the 23 March 1994 on the approximation of the laws of the Member States concerning equipments and protective systems intended for use in potentially explosive atmosphere.
- DPR 23/3/98 n°126: "Regulation which contains the standards to actuate the Directive 94/9/CE".
- Directive ATEX 2014/34/UE of 26 February 2014 concerning the harmonization of the laws of the Member States related to the equipment and the systems of protection intended to be used in a potentially explosive atmosphere.

Standard Body

- UNI CEI EN ISO 80079-36:2016 : Non-electrical equipment for explosive atmospheres –basic method and requirements; substitutes UNI EN 13463-1: 2009: Non-electrical equipment for use in potentially explosive atmosphere – Part 1: Basic concepts and requirements.
- UNI CEI EN ISO 80079-37:2016 : Non-electrical equipment for explosive atmospheres – Constructional safety "c", control of ignition sources "b", liquid immersion "k"; substitutes UNI EN 13463-5: 2011: Non-electrical equipment for use in potentially explosive atmosphere – Part 5: Protection by constructional safety "c".
- UNI EN 1127-1: 2011: Explosive atmospheres: Explosion prevention and protection. Part 1: Basic concepts and methodology.
- UNI EN 4413-2012: Hydraulic Fluid Powers – General rules and safety requirements for systems and their components.

Explosion risk assessment

Risks analysis

Different types of explosion risks are linked to the DPC130X working conditions.

This is equipment has to be assembled in environments classified as AREA 1 or AREA 21 or in M2 category mining environments, that is to say environments where the presence of combustible gases in air or of flammable dust, which may form a potentially explo-sive airborne cloud, is to be considered occasional during the regular plant working.

From this point of view, also in case of **predictable malfunction**, the equipment, has not to be an ignition source for the possible present explosive atmosphere.

The EPLs were chosen in accordance with possible ignition sources and normal operation and expected malfunctions analysis (Explosion Risk Assessment).

Walvoil supplies DPC130X in category 2G, 2D and for some product types in category M2 as well.

Therefore with reference to the service and maintenance manual, please note that the installer and the user are requested to choose all the certified mechanical and electrical components, to be assembled on the equipment accordingly:

- category 2G (ZONE 1), or
- category 2D (ZONE 21), or
- category M2.

In case of maintenance or cleaning operations, the user has to be sure to be far from a potentially explosive area.

Ignition hazard assessment

As for the possible ignition risk assessment, the analysis of the different equipment constructive drawings and the analysis of their functionality have seen carried out, by considering all the predictable malfunctions in compliance with the Directive.

In particular, all the possible ignition sources (suggested by the standard UNI EN 1127-1 and according to UNI EN 80079-36) have seen considered and, for each of them, the technical or operational measures adopted in order to make the ignition source not effective.

More in details (with reference to the selected categories):

- all the relevant parts, exposed to the explosion risk, have been evaluated for the risk from falling material or accidental impact and they meet the essential requirements (see impact test);
- the determination of the surface temperature and of the electrostatic risk, the service and maintenance manual indications, the marking and the application of the preventive and protective measures for all the potential ignition sources.

The DPC130X valves will be supplied in ATEX configuration with a maximal surface temperature defined with a wider range that the one verified during the tests.

The DPC 130X valves will be supplied as follows:

Marking:

 CE  II 2G Ex h IIC T4 Gb

 CE  II 2D Ex h IIIC T130°C Db

Without MS unloader valve mounted on the control valve:

 CE  I M2 Ex h I Mb

All the accessories are marked ATEX of a category suitable to the area of use and of limit temperature class T4 e T130°C.

Working AREA: **ZONE 1 or ZONE 21 or M2**

Dimensional data and performance

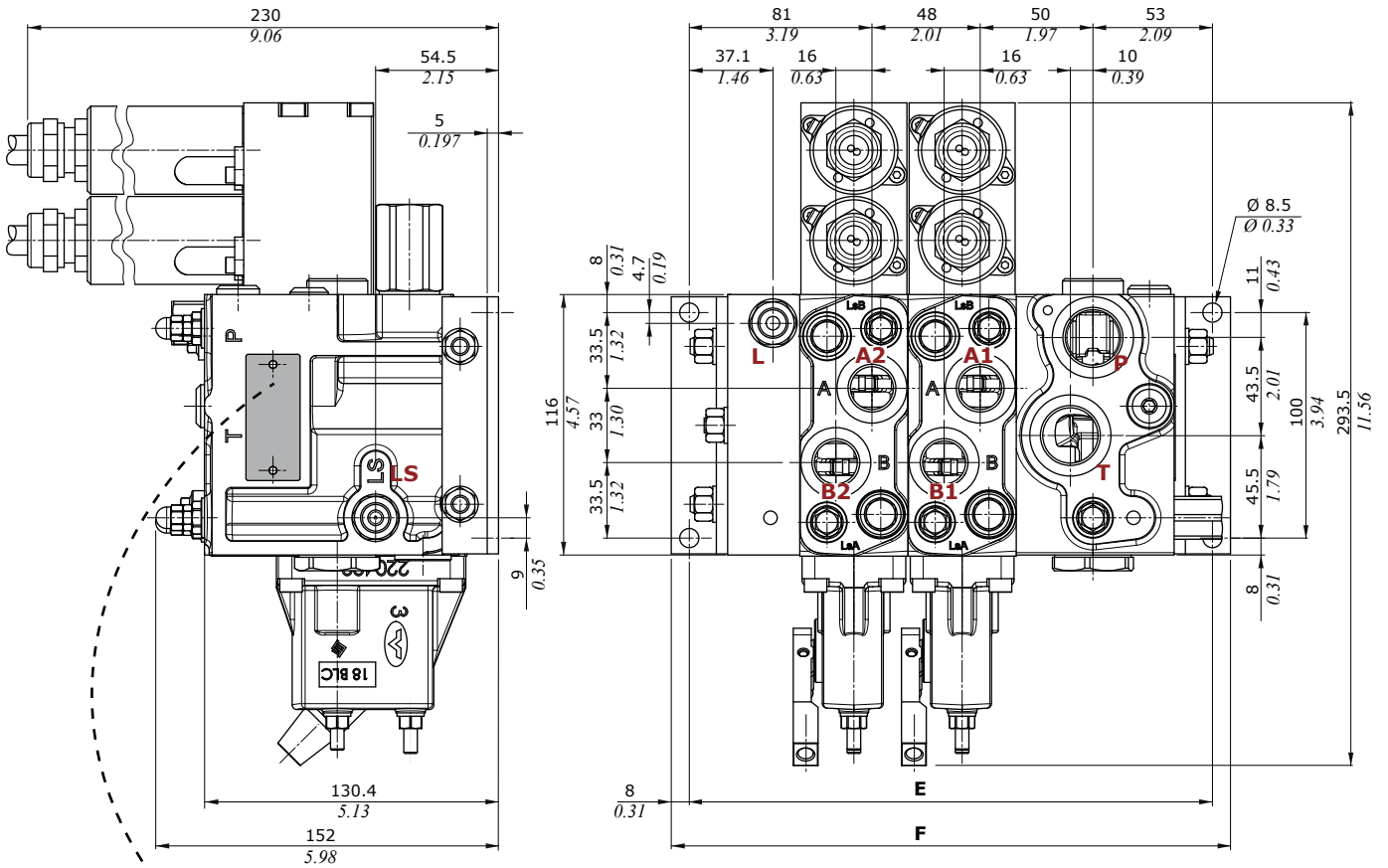

manufacturer reference

walvoil Via Adige 13/D 42124 Reggio E. Italy

product name
product code
product serial number
(production year included)
ATEX category
environmental temperature

DPC130X/6
161X60001
PA1801568/001

II 2G Ex h II T4 Gb - II 2D Ex h IIIC T130°C Db
I M2 Ex h Mb - T amb -20÷60°C T fluid -20÷80°C

CE Ex

DATAMATRIX
CE mark
ATEX mark
fluid temperature

P⇒T Pressure drop inlet compensator (margin pressure)

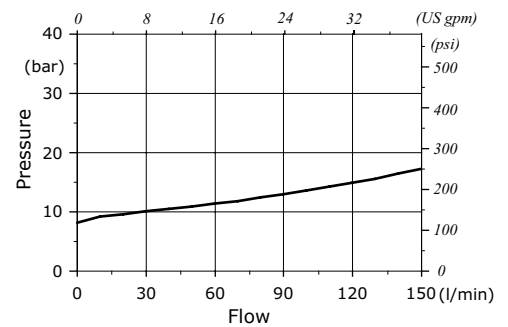

A(B)⇒T pressure drop (standard spool @ max.stroke)

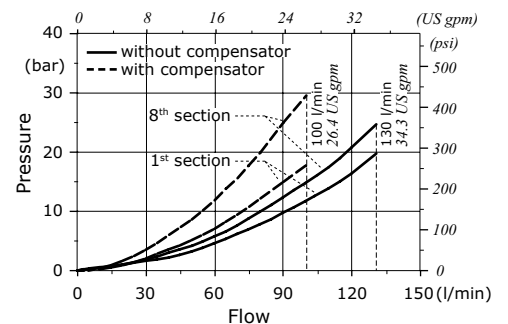

Type	E		F		Weight	
	mm	in	mm	in	Kg	lb
DPC130/1	184	7.24	200	7.87	12.4	27.3
DPC130/2	232	9.13	248	9.76	19.4	42.8
DPC130/3	280	11.02	296	11.65	25.3	55.8
DPC130/4	328	12.91	344	13.54	31.0	68.3
DPC130/5	376	14.80	392	15.43	36.5	80.5
DPC130/6	424	16.69	440	17.32	42.6	93.9
DPC130/7	472	18.58	488	19.21	48.7	107.0
DPC130/8	520	20.47	536	21.10	54.8	121.0
DPC130/9	568	22.36	584	22.99	60.9	134.0
DPC130/10	616	24.25	632	24.88	67.0	148.0

Complete section ordering codes

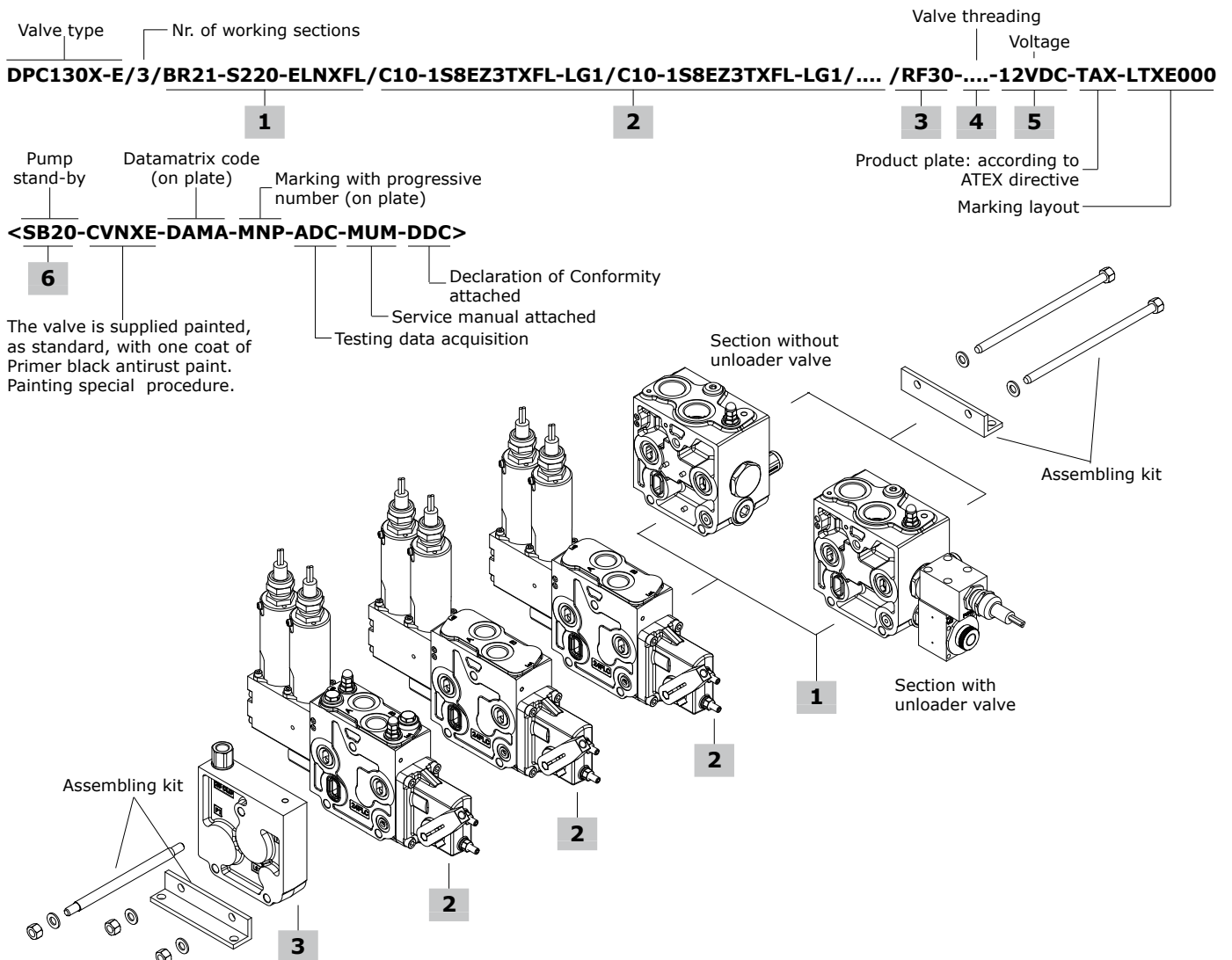

Tie rod tightening
wrench 13 - 30 Nm (22 lbft)

NOTE - Sections listed below are for example; for further section configurations and ordering codes please ask to Sale Department.

- 1 Inlet section**
 - Closed Center circuit**
 - TYPE: **DPC130/BN21-S220**
 - DESCRIPTION: With secondary pressure control system and pressure reducing valve, with L.S. pressure relief valve.
 - TYPE: **DPC130/BR21-S220-ELNXFL-12VDC**
 - DESCRIPTION: As previous one, with pressure reducing valve, and 12VDC solenoid operated unloader valve
 - Open Center circuit**
 - TYPE: **DPC130/BN11-S220**
 - DESCRIPTION: With 3-way compensator and L.S. pressure relief valve, without pressure reducing valve
 - TYPE: **DPC130/BR11-S220-ELNXFL-12VDC**
 - DESCRIPTION: As previous one, with pressure reducing valve, and 12VDC solenoid operated unloader valve.
 - For unloader valve specification, see page 12

- 2 Working section**
 - TYPE: **DPC130/C10-1S8EZ3TXFL-LG1-12VDC**
 - DESCRIPTION: With 2 way compensator, double acting spool for 60 l/min (16 US gpm), proportional electrohydraulic control with lever
 - TYPE: **DPC130/C22-1S8EZ3TXFL-LG1.UTUTSTST-12VDC**
 - DESCRIPTION: As previous one, arranged for port valves and L.S. relief valves
 - For more controls according to ATEX directive please see from pages 14 to 17

- 3 Outlet section**

TYPE	DESCRIPTION
DPC130/RF10	Without ports; for valve with mechanical control
DPC130/RF20	Without ports, internal drain; for valve with hydraulic control
DPC130/RD31	With P1 and T1 ports (plugged), LS1 port, L external drain; for valve with electrohydraulic control

Inlet section

Solenoid operated L.S. unloader valve

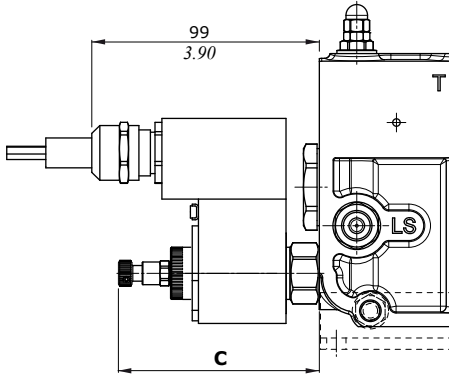

Valve type	Dim. C	
	mm	in
ELN	65.5	2.58
ELP	88.5	3.48
ELV	88.5	3.48
ELT	91	3.58

Valve features

Max. flow: 40 l/min (10.6 US gpm)
 Max. pressure: 380 bar (5500 psi)
 Internal leakage: 0.25 cm³/min @ 210 bar
 (0.015 in³/min @ 3050 psi)

Coil features

Nominal voltage: 12VDC / 24 VDC ±10%
 Power rating: 30 W
 Coil insulation: Class H (180°C - 356°F)
 Weather protection: IP66
 Insertion: 100%

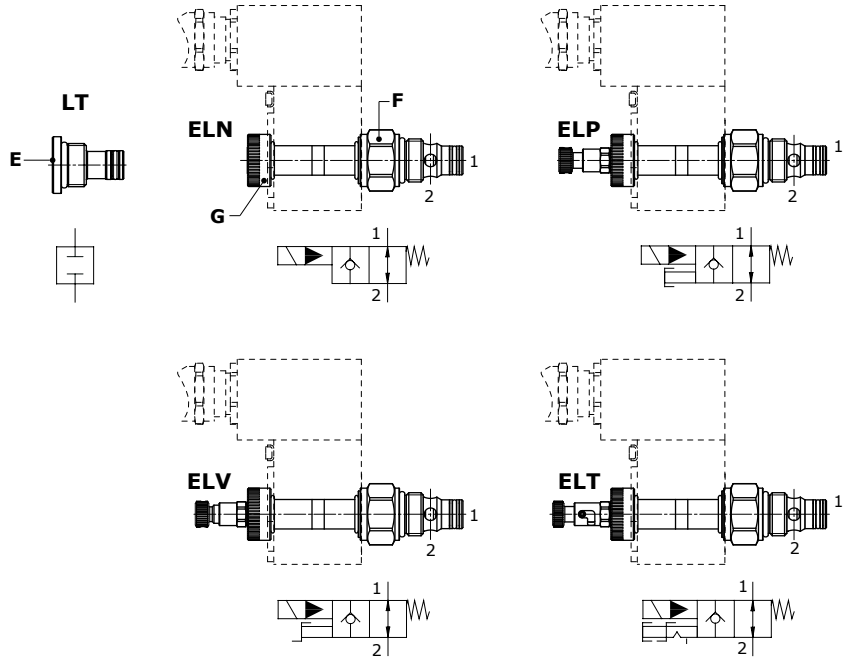

Legenda

- ELN: without emergency
- ELP: push button emergency override
- ELV: screw emergency override
- ELT: "push&twist" emergency override
- LT: valve blanking plug

Wrenches and tightening torques

- E = wrench 10 - 24 Nm (17.7 lbf)
- F = wrench 24 - 30 Nm (22 lbf)
- G = manual tightening

"A" side spool control kit

With spring return to neutral position: 8 type

It is supplied with standard spring A type (see force-stroke diagram); available with stronger spring C type (8MC code: 5V08230000).

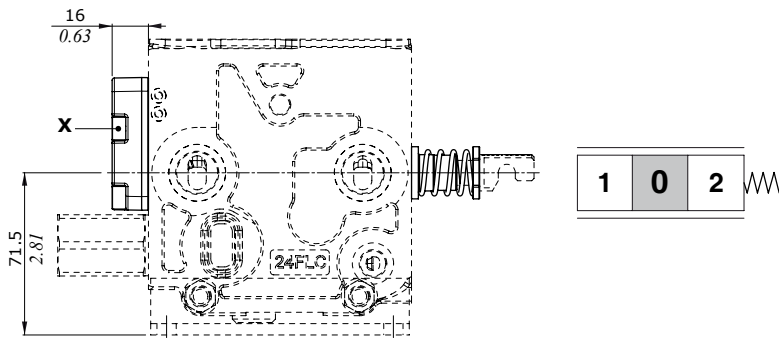

Wrenches and tightening torque

X = allen wrench 5 - 9.8 Nm (7.2 lbf)

Force vs. Stroke diagram

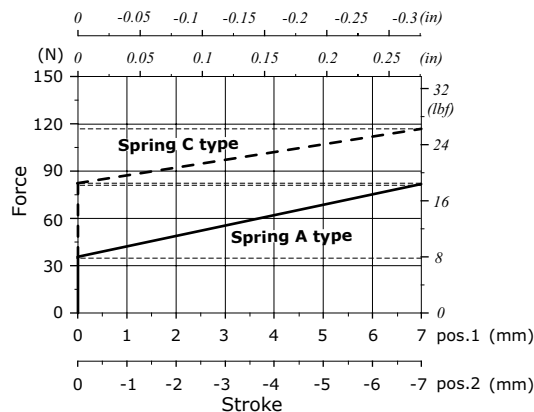

Spring A type = from 35.6 N (8 lbf) to 81.8 N (18.4 lbf)
 Spring C type = from 82.3 N (18.5 lbf) to 116.8 N (26.3 lbf)

With detent in 4th position (pos.3), for floating circuit: 13 type

F, G or FV type working sections and floating circuit 5 type spool are requested for.

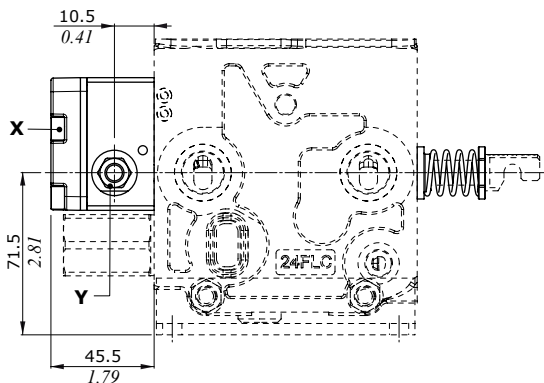

Features

Detent force (±10%) : 310 N (70 lbf)
 Release force (±10%) : 110 N (24.7 lbf)

Wrenches and tightening torque

X = allen wrench 5 - 9.8 Nm (7.2 lbf)
 Y = wrench 13 - 24 Nm (17.7 lbf)

Working section

"A" side spool control kit

Proportional hydraulic controls: IMO type

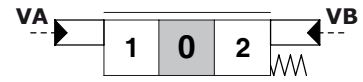
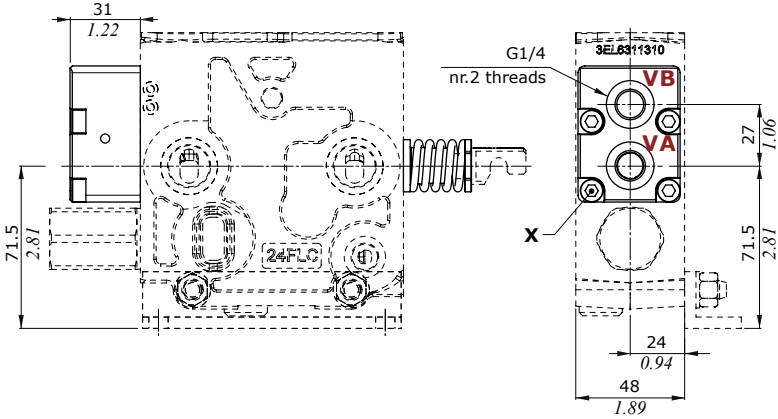

Features

Max. pressure. : 50 bar (725 psi)

Wrenches and tightening torque

X = allen wrench 5 - 9.8 Nm (7.2 lbf)

Y = wrench 13 - 24 Nm (17.7 lbf)

Stroke vs. Pressure diagram

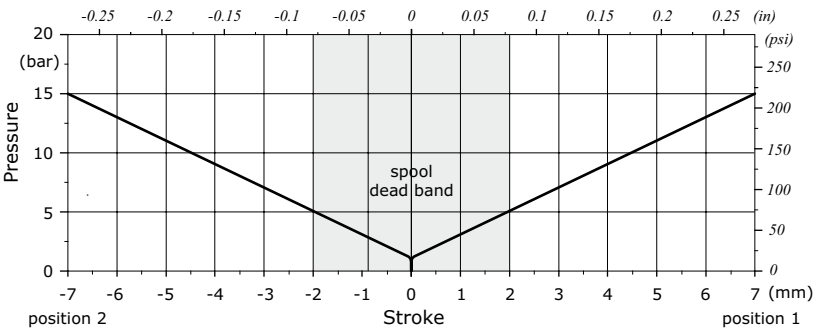

Suggested pressure control curve: 020 type

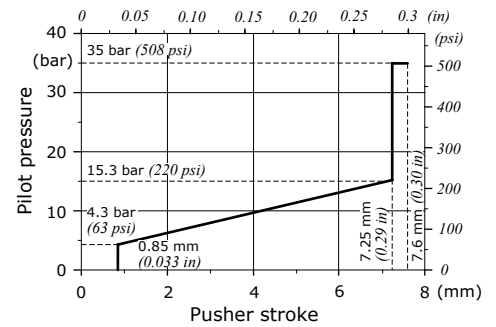

"A" side spool control kit

Proportional electrohydraulic control: 8EZ3TXFL type

Following specifications are measured with:

- mineral oil of 46 mm²/s (46 cSt) viscosity at 40°C (104°F) temperature,
- 20°C (60°F) environmental temperature,
- standard spools, connecting P→A→B→T ports without flow multiplication,
- 12 VDC and 24 VDC nominal voltage with ± 10% tolerance.

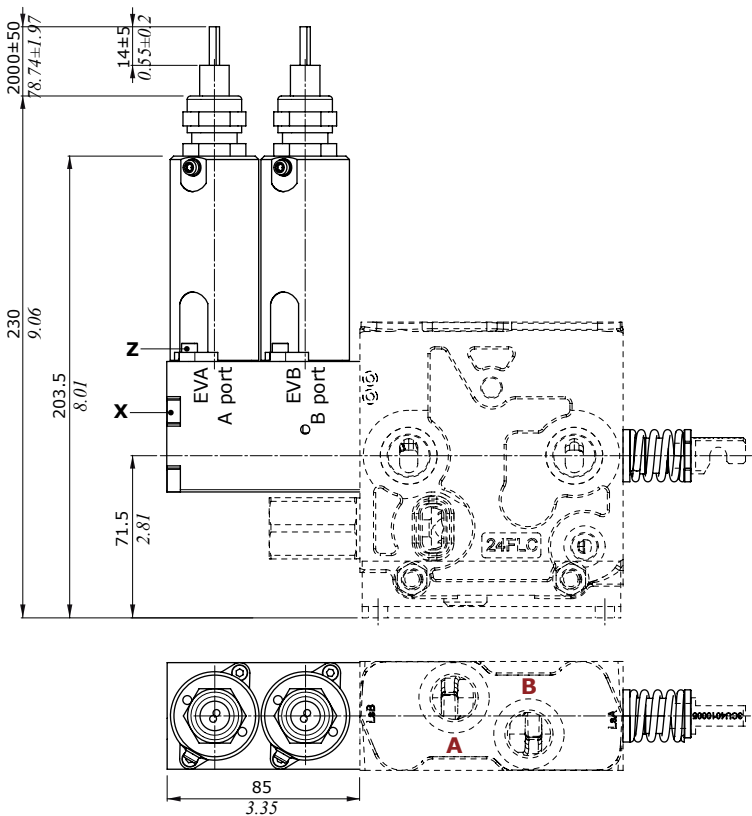

Features	12 VDC	24 VDC
Coil impedance	5.3 Ω	21.2 Ω
Max. operating current	1.5 A	0.75 A
Min. flow control signal	500 mA	250 mA
Max. flow control signal	1000 mA	500 mA

- Hysteresis max.⁽¹⁾ (external drain) : < 10%
- Time response (from 0 ⇒ 100% and from 100% ⇒ 0) : < 150 ms
- Dither frequency (high frequency) : 100 Hz (200 mA)
- Insertion : 100%
- Coil insulation ⁽²⁾ : -----
- Connection type : flying leads
- Weather protection : IP69K
- Max. pressure : 50 bar (725 psi)
- Max. back pressure on drain : 2.5 bar (36 psi)

Note (1) For the calculation rules please see "Appendices" section on page 107.
 Note (2) Not available; operating temperature according to ATEX directive.

Wrenches and tightening torque

- X = allen wrench 5 - 9.8 Nm (7.2 lbf)
- Z = allen wrench 3 - 5 Nm (3.7 lbf)

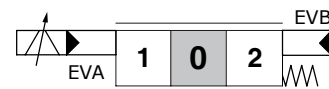

Stroke vs. Current diagram

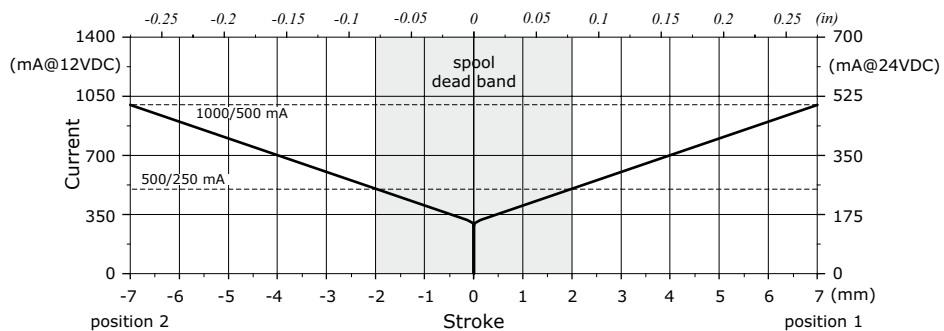

Working section

"B" side spool control kit

Cast iron lever box; LG type

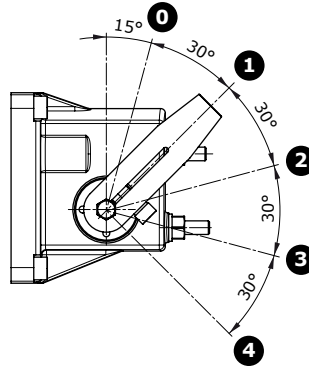
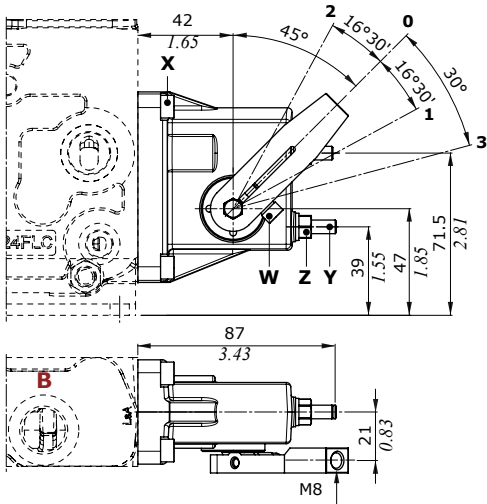
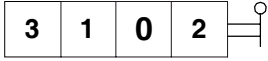

Lever assembly position
Please see page 90 for specification
in working section description

Wrenches and tightening torque

X = allen wrench 5 - 9.8 Nm (7.2 lbf)

Y = allen wrench 3

Z = wrench 10 - 9.8 Nm (7.2 lbf)

W = allen wrench 4 - 6.6 Nm (4.9 lbf)

Main rules

The DPC Series valves are assembled and tested as per the technical specifications of this catalogue.

Before the final installation on your equipment, please follow the below recommendations:

- the valve can be assembled in any position; in order to prevent body deformation and spool sticking mount the product on a flat surface;
- In order to prevent the possibility of water entering the spool control kit, do not use high pressure washdown directly on the valve;
- prior to painting, ensure plugs on normally open ports are tightly in place.

WARNING: for painting refer always to the guidelines included in the User and Maintenance Manual supplied with the product

- per indicazioni dettagliate in merito all'installazione e all'impiego consultare sempre il Manuale d'uso e manutenzione.

for detailed instructions about the installation and use always refer to the User and Maintenance Manual.

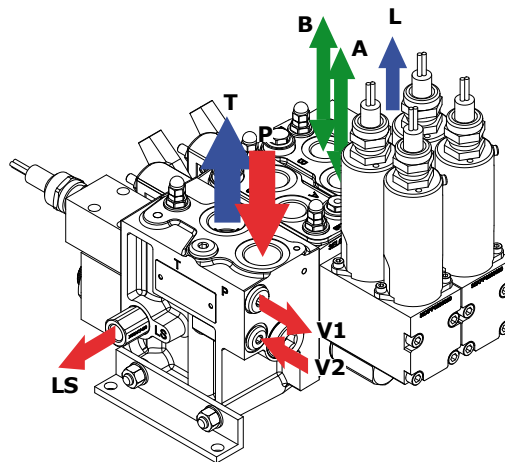
**FITTINGS TIGHTENING TORQUE - Nm / lbft**

THREAD TYPE	P inlet port	A and B workports	T outlet port	LS signal port V pilot ports*	L drain port	Hydraulic control ports
BSP	G 3/4	G 1/2	G 3/4	G 1/4	G 1/4	G 1/4
With O-Ring seal	90 / 66.4	50 / 36.9	90 / 66.4	25 / 18.4	25 / 18.4	25 / 18.4
With copper washer	90 / 66.4	60 / 44.3	90 / 66.4	30 / 22.1	30 / 22.1	30 / 22.1
With steel and rubber washer	70 / 51.6	60 / 44.3	70 / 51.6	16 / 11.8	16 / 11.8	16 / 11.8
UN-UNF	1 1/16-12 (SAE 12)	7/8-14 (SAE 10)	1 1/16-12 (SAE 12)	9/16-18 (SAE 6)	9/16-18 (SAE 6)	9/16-18 (SAE 6)
With O-Ring seal	95 / 70	50 / 36.9	95 / 70	30 / 22.1	30 / 22.1	30 / 22.1

(*) V2 port is M14x1.5 threading: tightening torque value is the same of G1/4 thread

NOTE – These torque are recommended. Assembly tightening torque depends on many factors, including lubrication, coating and surface finish.



- Directive 94/9/EC -
Equipment and protective systems for use
in potentially explosive areas



Acknowledgement

BVS 15 ATEX H/B 057

in accordance with article 8 (1) b) ii)
of having received the documentation in compliance with annex VIII number 3

Manufacturer: Walvoil S.p.A.
Address: Via Adige 13/d
42124 Reggio Emilia (RE), Italy

The certification body of DEKRA EXAM GmbH, notified body No. 0158 in accordance with article 9 of directive 94/9/EC of the European Parliament and of the Council of the European Communities of March 23, 1994, acknowledges to have received the documentation mentioned below on 2015-12-21.

Documentation on:
Hydraulic Sectional Control Valve, Type DPC130

The documentation is neither examined on sufficiency nor is it verified. It will be archived for a period of 10 years from the date of the acknowledgement. If the manufacturer desires to have the duration of archival storage extended, he is to duly communicate this in writing.

DEKRA EXAM GmbH
Bochum, 2015-12-21

Certification body

Special service unit



Innovation · Continuity · Integration
————— It is Power —————

 **walvoil**
FLUID POWER E| MOTION

 **walvoil**

 **hydro control**

 **Caltex**

D1WWED03E
2nd edition September 2018

Walvoil S.P.A. • 42124 Reggio Emilia • Italy • Via Adige, 13/D • Tel. +39.0522.932411 • Fax +39.0522.300984
www.walvoil.com

